



MODEL NUMBER: XRL900-1-0-GB-XX

IMPROX REGISTRATION INTERFACE

ImproX (RL) Registration Interface INSTALLATION MANUAL

SPECIFICATIONS

| | | |
|----------------------------------|--|------------------|
| Working Environment | The ImproX RL is designed to work in an indoor (dry) environment similar to IP20. The ImproX RL is, therefore, NOT sealed against water. | |
| Scanner Operation | 125 kHz. | |
| Input Voltage | 10 V DC to 30 V DC. | |
| Power Requirements | Current (mA) | Power (W) |
| Input Voltage 10 V DC | 210 | 2.1 |
| Third-party Port | 5 V DC \pm 0.1 V is supplied to power the single Reader connected to this Port. A maximum of 100 mA can be supplied from this Port. | |

Installer Interfaces

| | |
|------------------------|--|
| Registration Interface | |
| Status Indicator | |
| Power LED | Blue (steady) (externally visible). |
| Diagnostic Indicators | |
| USB Tx LED..... | Red (flashing) (internally visible). |
| USB Rx LED | Green (flashing) (internally visible). |
| RS485 Tx LED | Red (flashing) (internally visible). |
| RS485 Rx LED..... | Green (flashing) (internally visible). |
| ImproX RRA or RRM | |
| Status Indicator | |
| Status LED..... | Bi-colour, Red or Green LED. |
| Buzzer | |
| Volume and Tone | Four volume, single tone (Software dependent). |

INSTALLATION INFORMATION

Accessories

Find the following when unpacking the Registration Interface:

- An ImproX (RL) Registration Interface housed in a Black, Aluminium extruded Cabinet. The ImproX RL consists of a Top Cover, a Base and two End Plates (each End Plate is attached with three Thread Cutter Screws (M3 x 8 mm)).
- Four Brass Wood Screws (3.5 mm x 25 mm).
- Four Wall Plugs (7 mm).
- A 1.8 m (5.90 ft) standard USB Cable with a Type A to Type B Connector.
- A MAC Address Label.
- An extra Fixed Address Label.

General

Remember the following when installing the Registration Interface:

Communications Distance

- The USB communications distance between the Host PC and the Registration Interface MUST NOT exceed 5 m (16.40 ft).
- DO NOT cut and join the supplied USB Cable. If extension of the USB Cable is required, source a new longer length USB Cable.

Distance between the Registration Interface and the ImproX RRM or ImproX RRA

The maximum cable distance between the ImproX Registration Interface and the ImproX RRM or ImproX RRA, MUST NOT exceed 2 m (6.56 ft).

Distance between ImproX RRAs or ImproX RRM's from DIFFERENT Registration Interfaces

To avoid mutual interference install the ImproX RRAs or ImproX RRM's no closer than 500 mm (20 in) apart.

Blank Space

Mounting the Cabinet

CAUTION: Make certain that you mount the Registration Interface on a vibration-free surface.

Select the mounting position of the ImproX RL, considering accessibility, routing of wires and visibility of the externally visible Power LED.

Secure the Cabinet to the mounting surface, using four suitable screws and wall plugs (supplied), nuts and bolts or rivets.

DIP-switch Settings

The format selection for each type of device that can be connected to the Third-party Port is made by setting the internal DIP-switches as indicated in Table 1.

NOTE: Terminals 'A' and 'B' in Table 1 are on the Third-party Port Terminal Block.









| DIP-switch Position | Format | Connections |
|--|----------------------------------|--|
| 0  DIP-switch 0 shows all the switches in the OFF position | No peripheral Reader | N/A |
| 1  DIP-switch 1 shows switches 2, 3 and 4 in the ON position | MIFARE® Remote (ImproX RRM) | Rx to terminal 'A' Tx to terminal 'B' |
| 2  | RF Receiver | Data Line to terminal 'B' |
| 3  | Magstripe ABA Track 2 | Data Line to terminal 'A' Clock Line to terminal 'B' |
| 4  | Barcode Code-39 with Checksum | Data Line to terminal 'B' |
| 5  | Barcode Code-39 without Checksum | Data Line to terminal 'B' |
| 6  | Wiegand 26/37/40 and 44 | 0 Data Line to terminal 'B' 1 Data Line to terminal 'A' |
| 7  | Wiegand Open Format | 0 Data Line to terminal 'B' 1 Data Line to terminal 'A' |

Table 1: DIP-switch Settings

NOTE: Once the DIP-switch setting is modified reset the ImproX RL to acknowledge the new settings.

CONNECTING THE REGISTRATION INTERFACE

Figure 1 shows a detailed connection diagram for the ImproX RL.

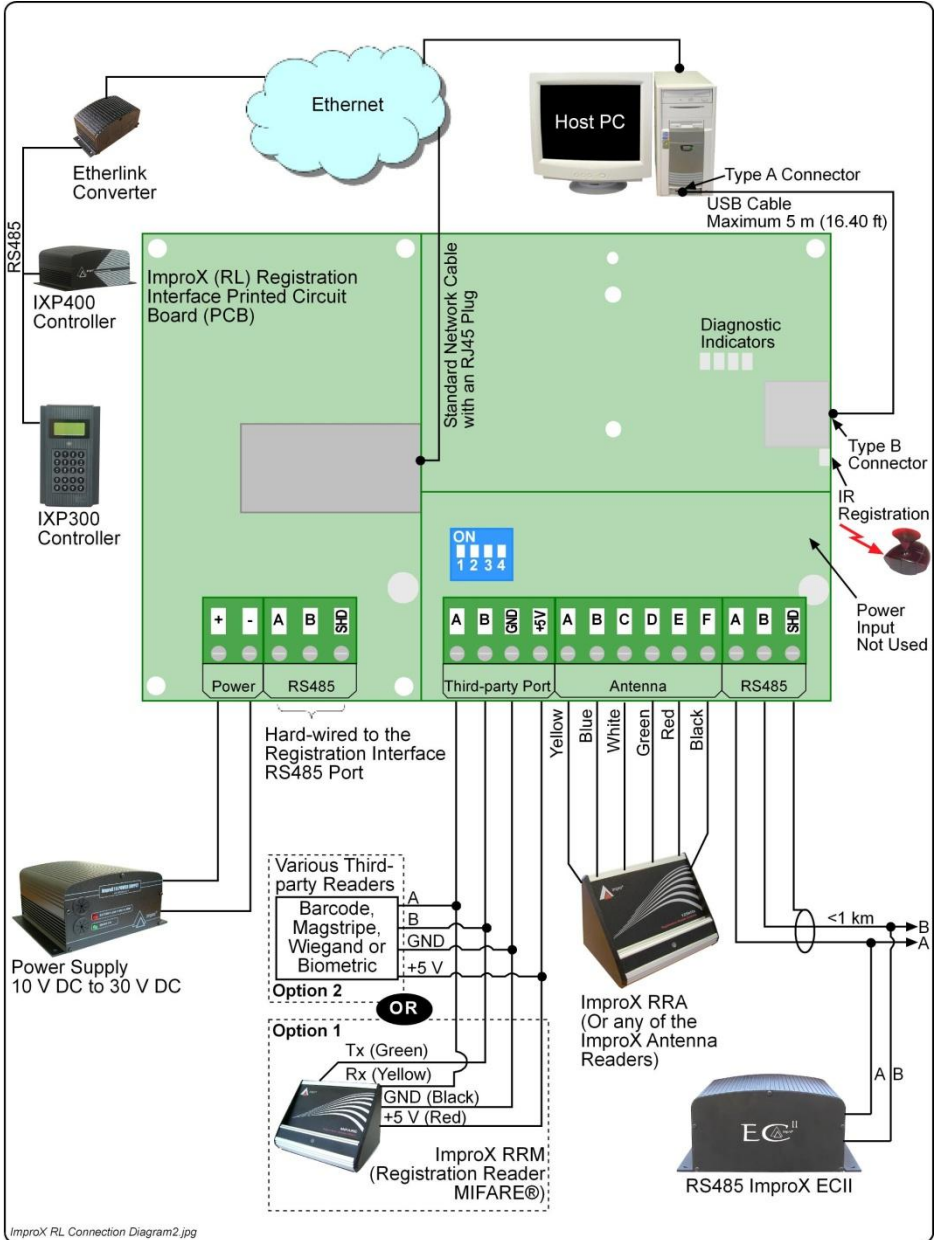

ImproX RL Connection Diagram2.jpg

Figure 1: Typical ImproX RL Electrical Connections

Power-on Self-test

The Power-on Self-test tests the RAM and Flash Checksums.

If any parameter in the Self-test fails, the Registration Interface emits a continuous beep for 2 seconds.

When the Registration Interface passes the Self-test, it emits two short beeps, each 200 ms in duration, separated by a 200 ms inter-beep pause.

Testing the Connection

When the Registration Interface is connected, check that the Power LED is illuminated Blue (steady). This will confirm that the connection is correct and working.

Fixed Address Label

Once the Registration Interface is installed, sketch a rough site plan. Attach the loose (additional Fixed Address Label packaged with the Registration Interface) Fixed Address Label in the position of the Registration Interface on the sketched site plan. When the system installation is complete and all the units are represented on the site plan by their Fixed Address Labels, file the site plan for future reference.

MAC Address

The MAC Address identifies the Lantronix® XPort™ component placed in each ImproX RL. The MAC Address and the description of the ImproX RL's location are required by the Software Installer to enable an IP Address to be assigned to the Registration Interface.

We recommend that you attach the MAC Address Label to the site plan in the ImproX RL's installed location.

GUARANTEE OR WARRANTY

This product conforms to our Guarantee or Warranty details placed on our Web Site, to read further please go to www.impro.net.

USER NOTES

USER NOTES

USER NOTES

USER NOTES

This manual is applicable to the ImproX (RL) Registration Interface, XRL900-1-0-GB-05. (The last two digits of the Impro stock code indicate the issue status of the product).

XRL300-0-0-GB-05

Issue 06

Apr 2009

ImproX RL\English Manuals\LATEST ISSUE\
ImprX RL-inism-en-06.docx